

Office Trailer

8x16

ATHOM[®]

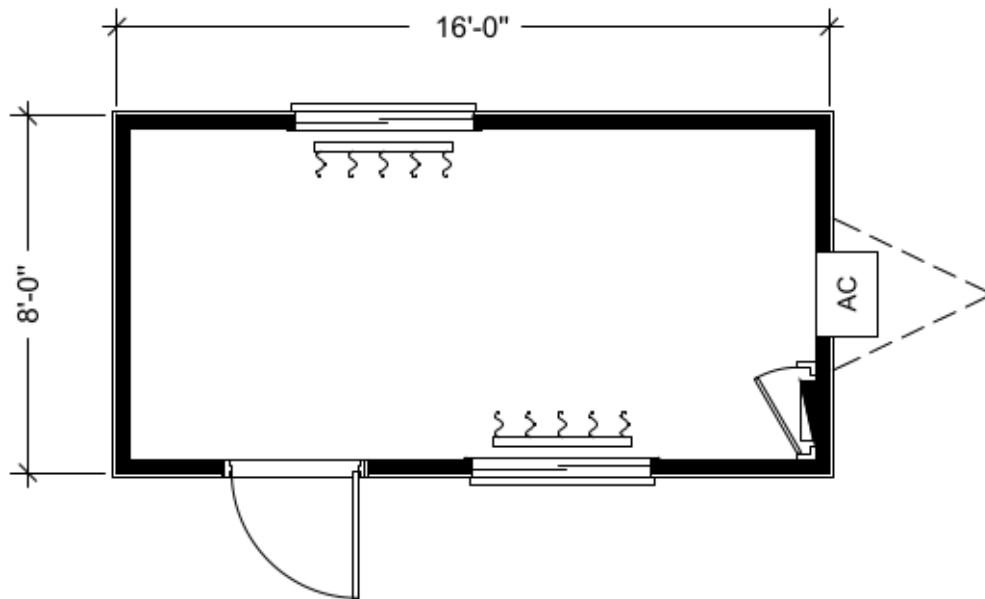

GENERAL SPECIFICATIONS

Length: 16'

Width: 8'

Height: 8'

Area: 128 ft²

Number of axles: 1

Number of doors: 1

Number of windows: 2

Interior divisions: 0

Electrical panel: 100 AMP, 24 circuits

Interior electrical outlets: 5

**Exterior electrical outlets: 1
(On some models)**

Air conditioning: 1 x 8000 BTU

Electric heating: 1500 watts