

Office Trailer

12x52

ATHOM[®]

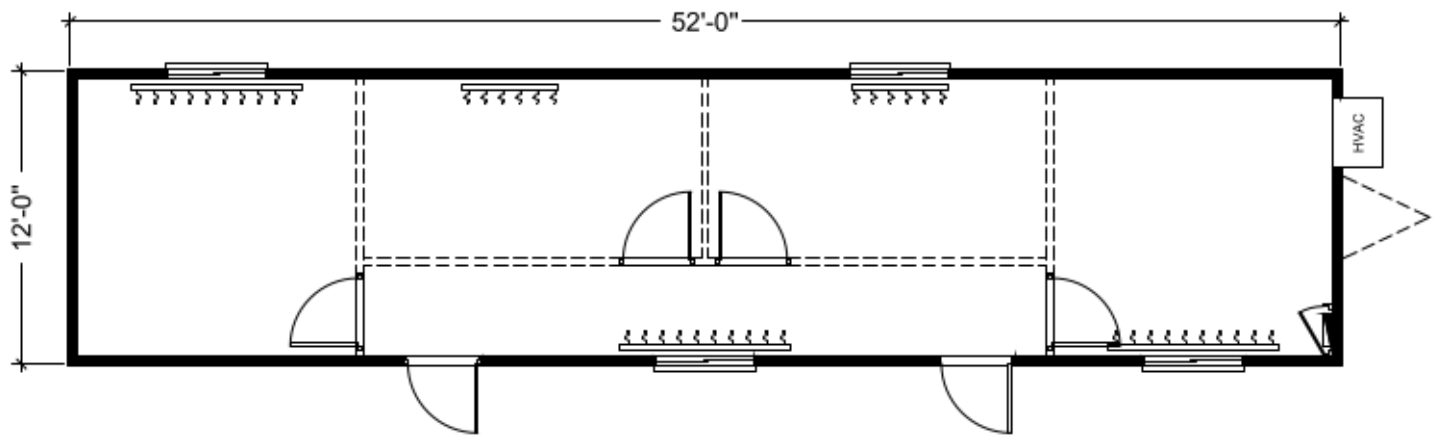

GENERAL SPECIFICATIONS

Length: 52'

Width: 12'

Height: 8'

Area: 624 ft²

Number of axles: 4

Number of doors: 2

Number of windows: 4

Interior divisions: 0 to 3

Electrical panel: 100 AMP, 24 circuits

Interior electrical outlets: 10

**Exterior electrical outlets: 1
(On some models)**

**Air conditioning: 2 tons,
5000 watts**

Electric heating: 8000 watts